

DO NOT SCALE
IF IN DOUBT, ASK

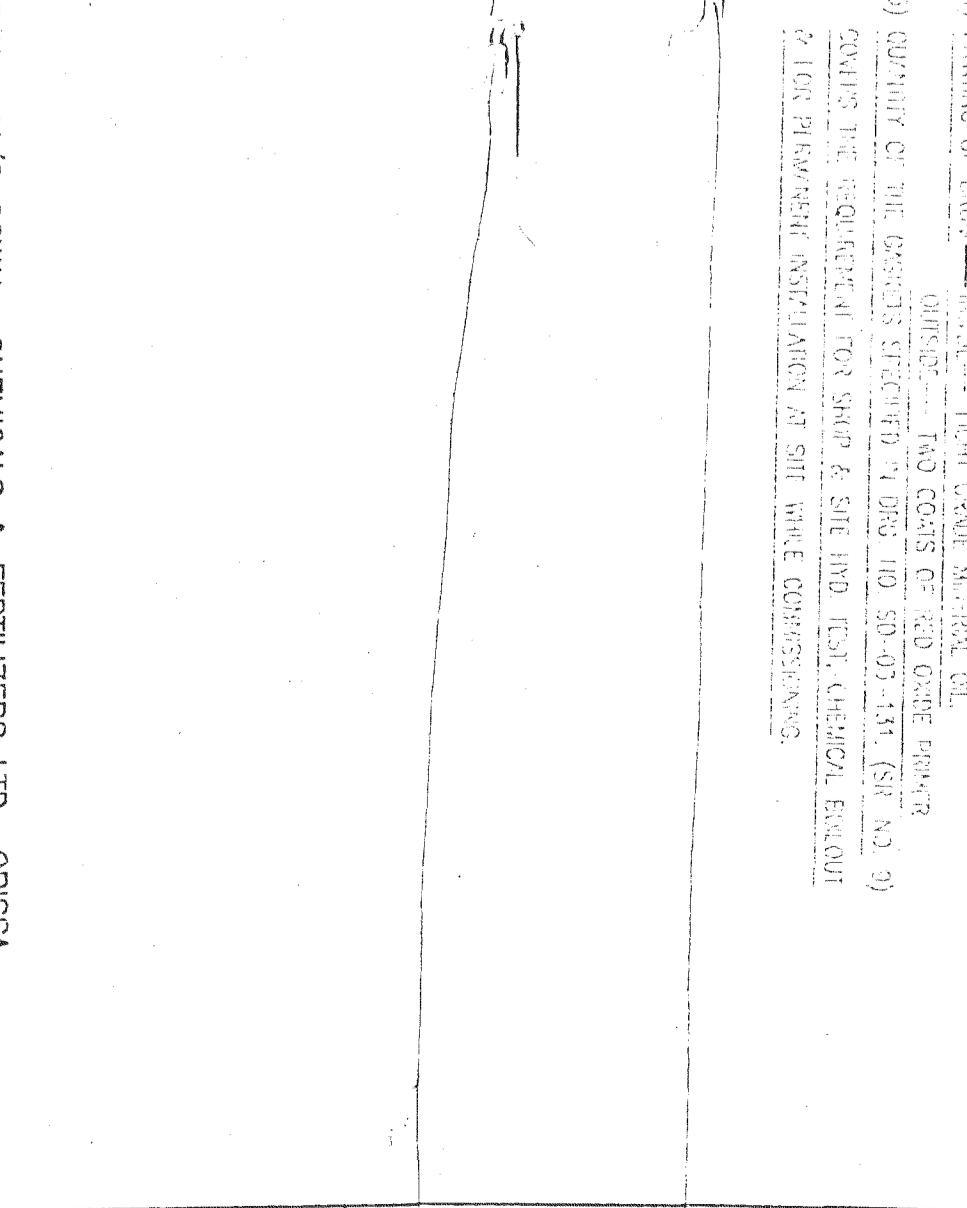
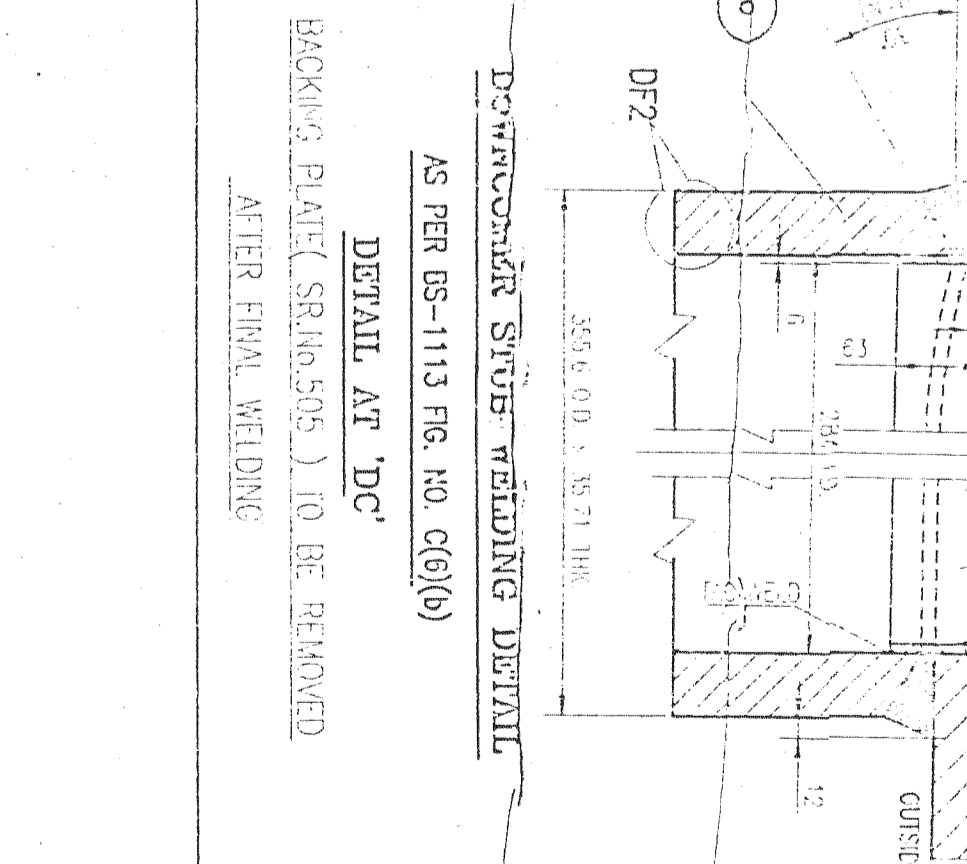
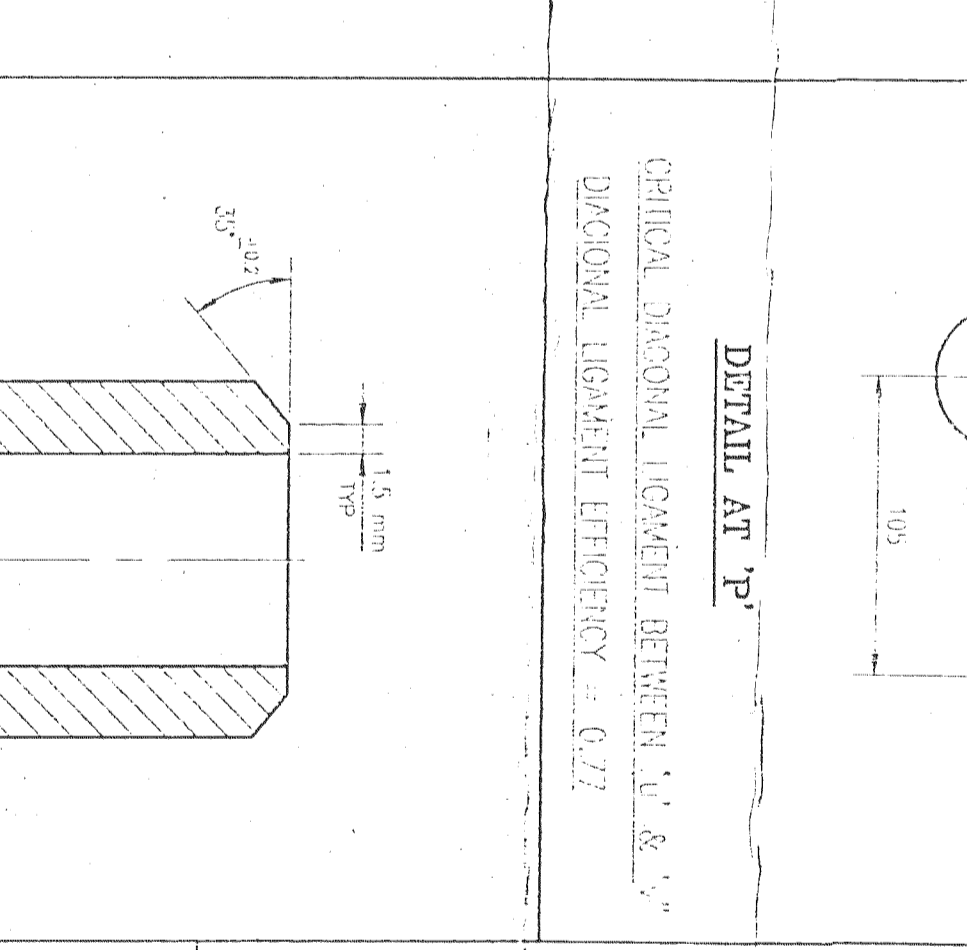
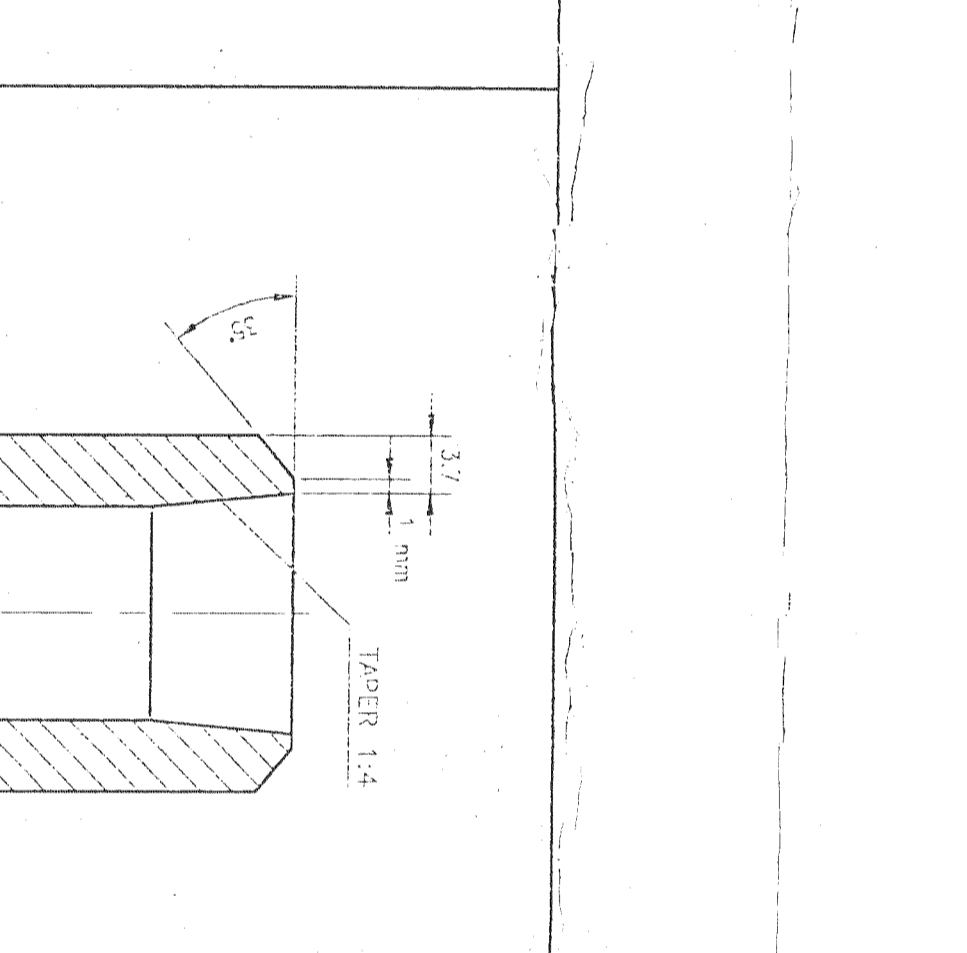
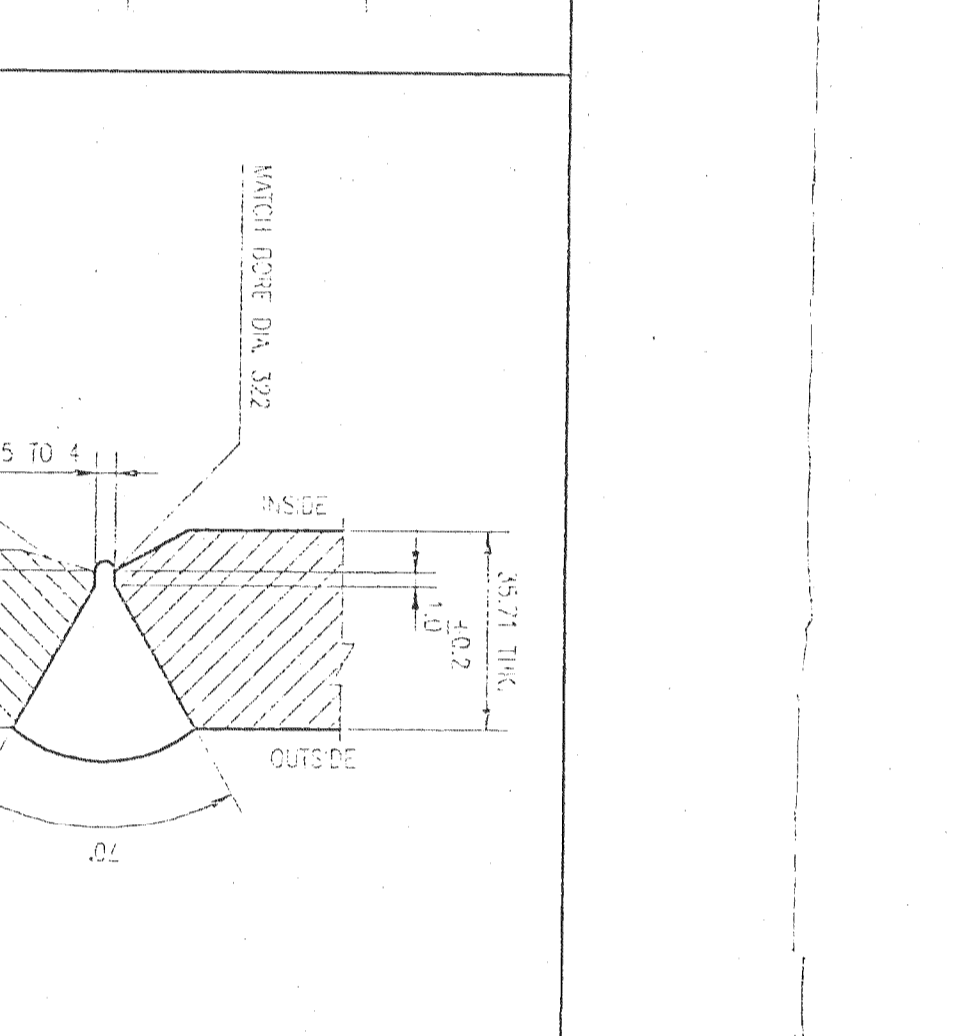
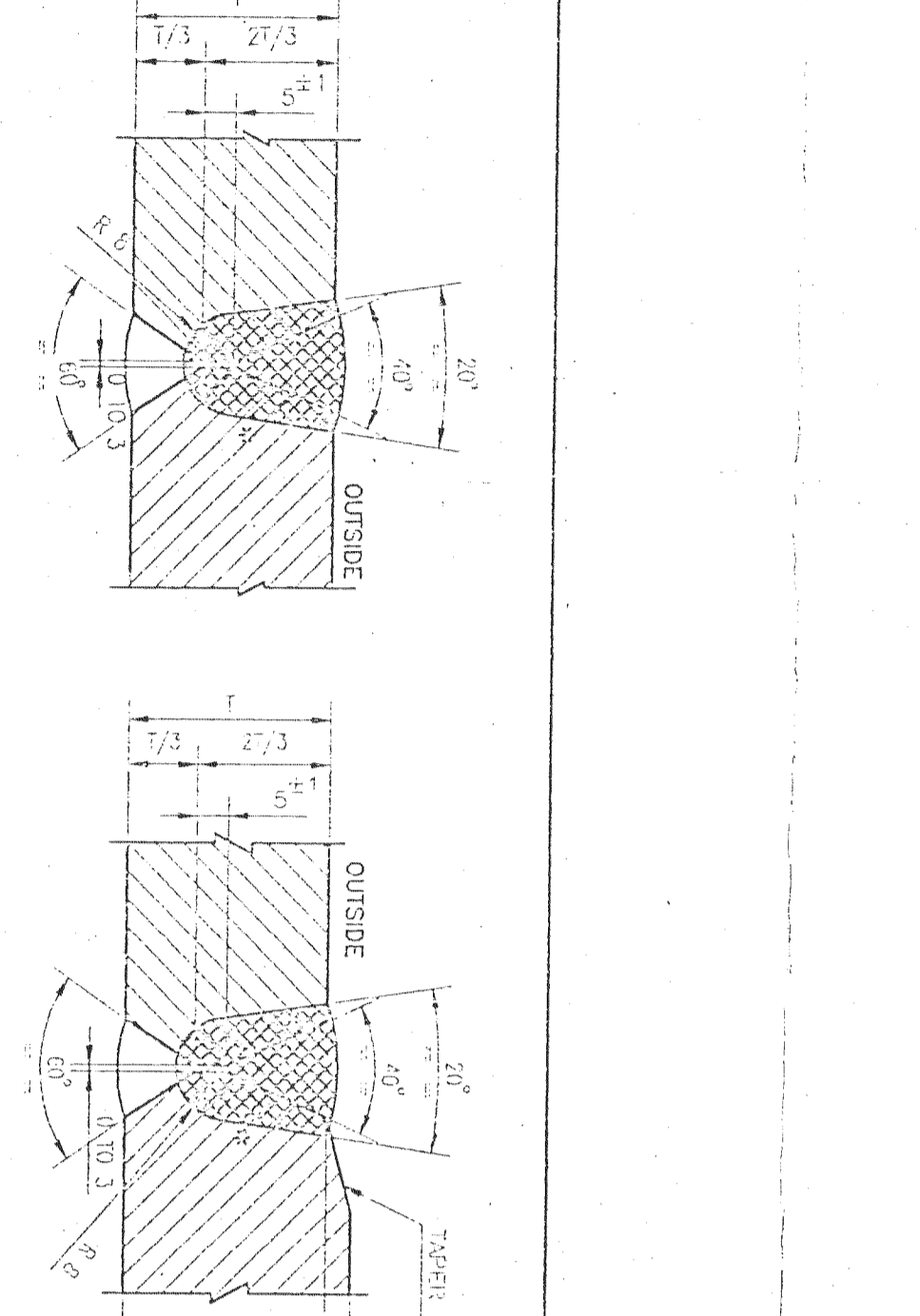
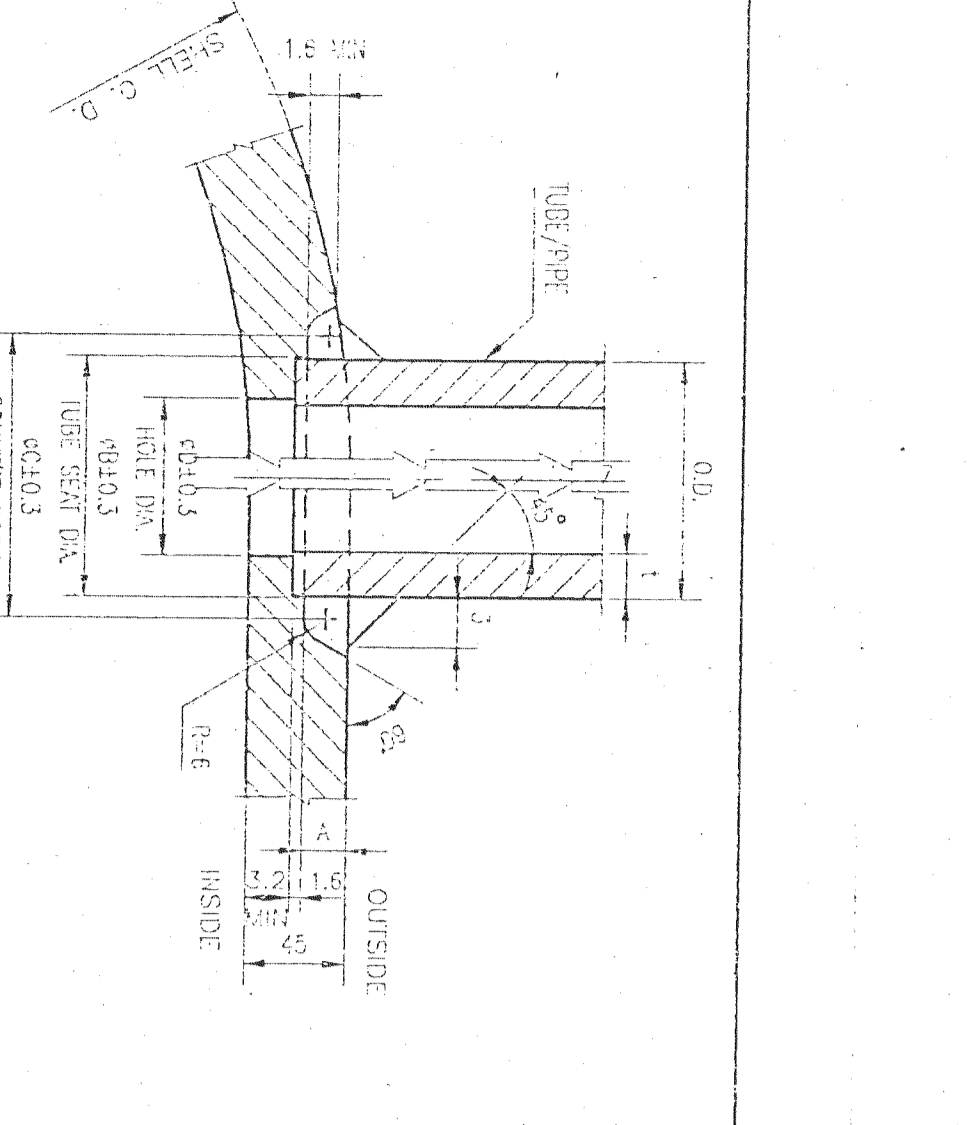
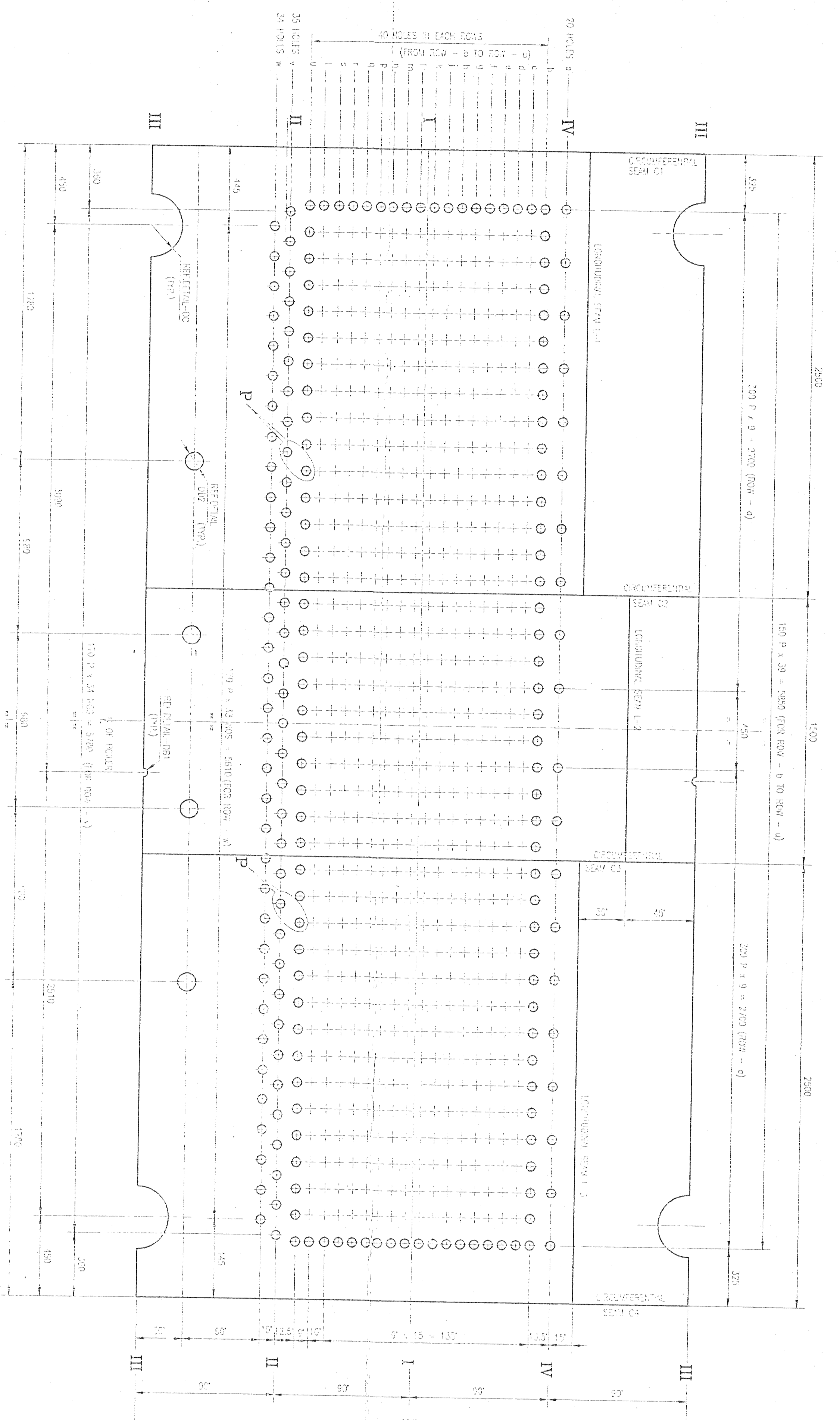
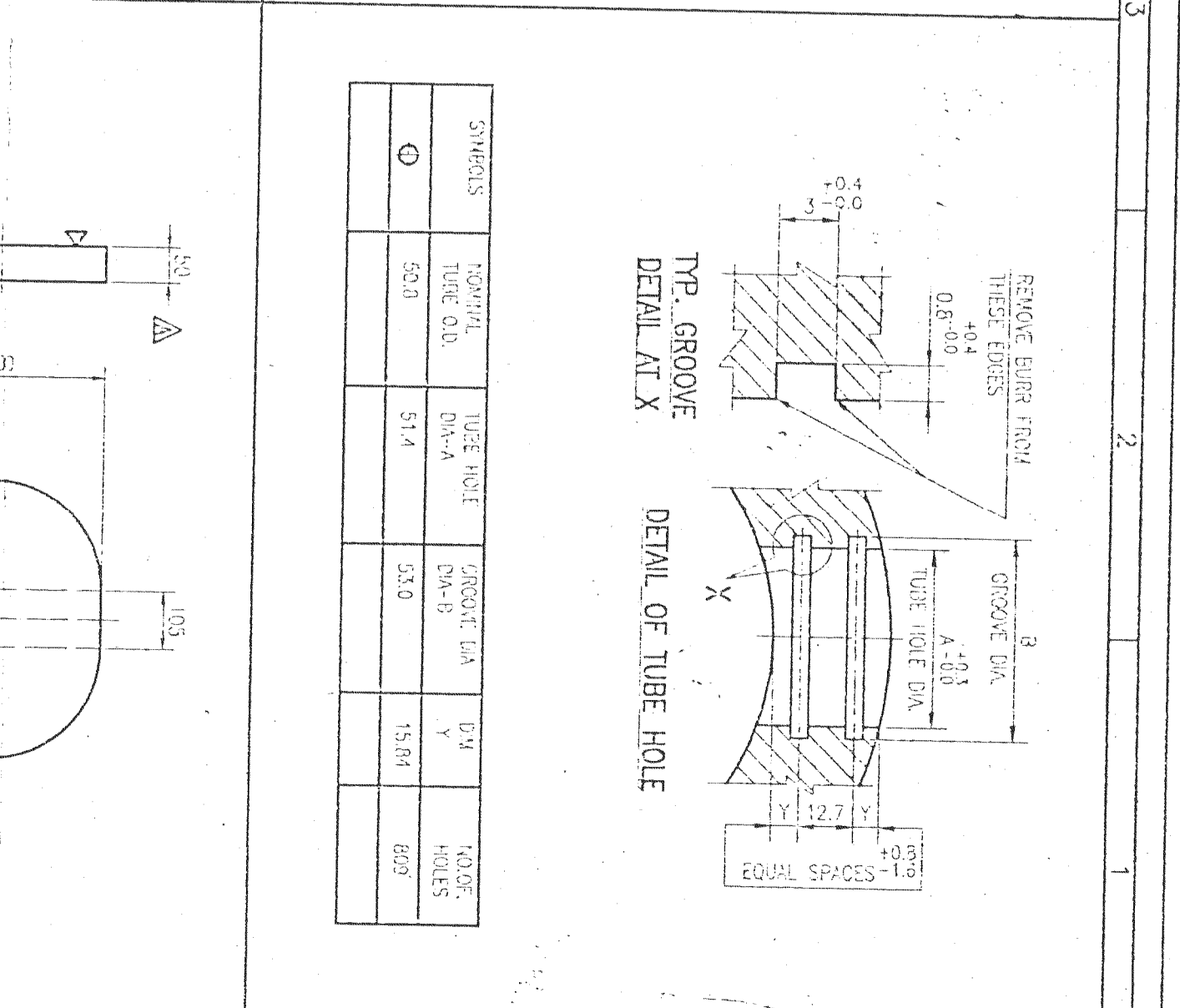
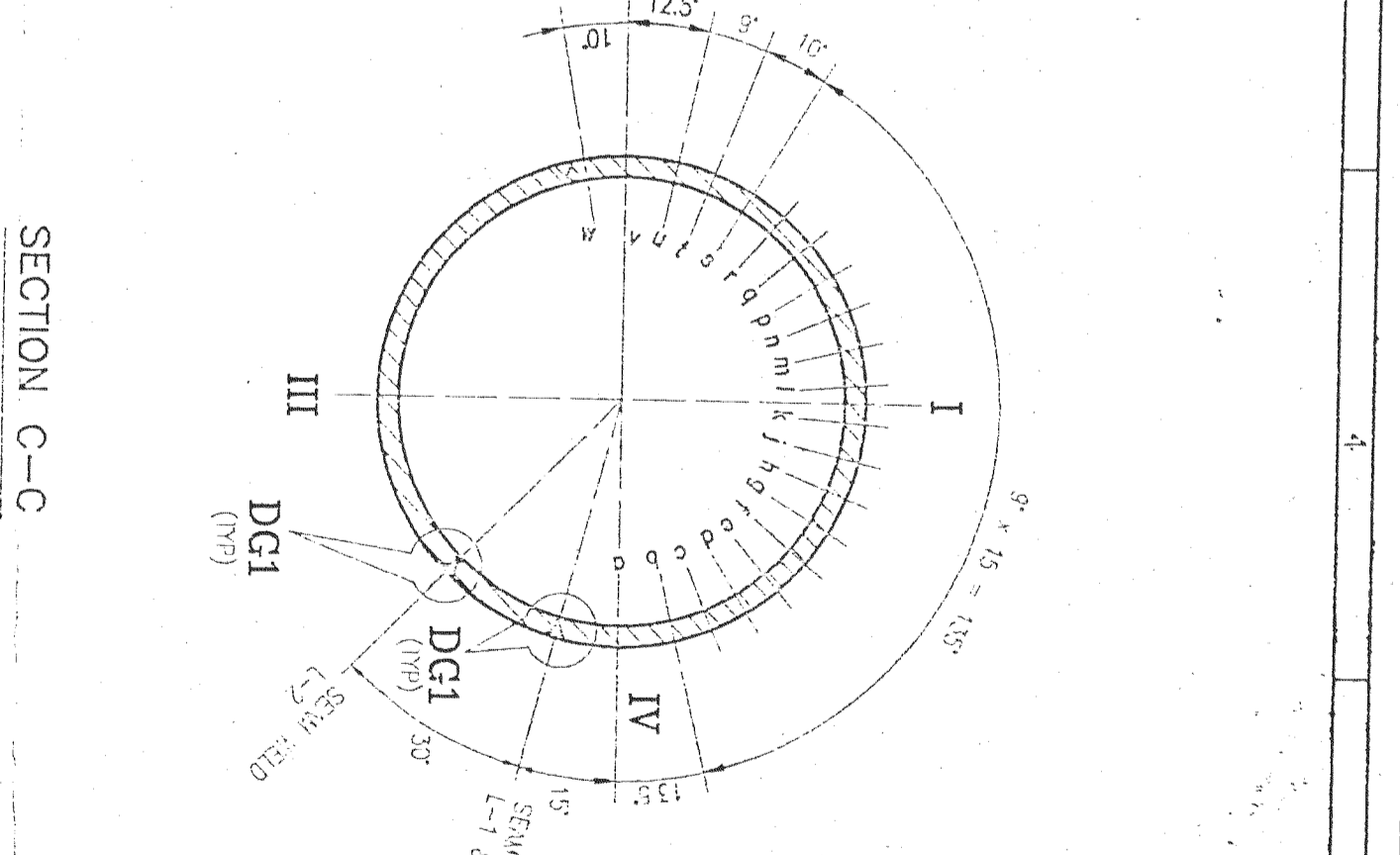
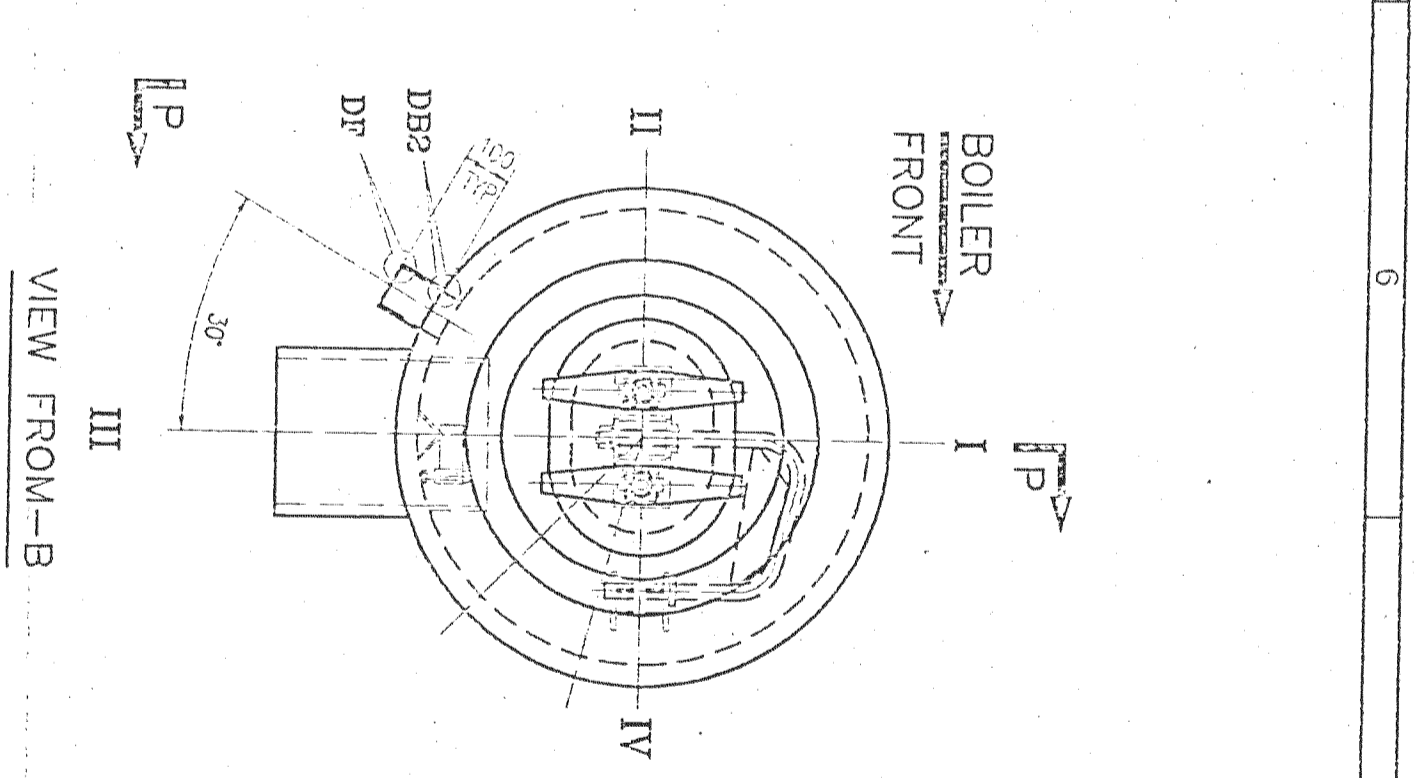
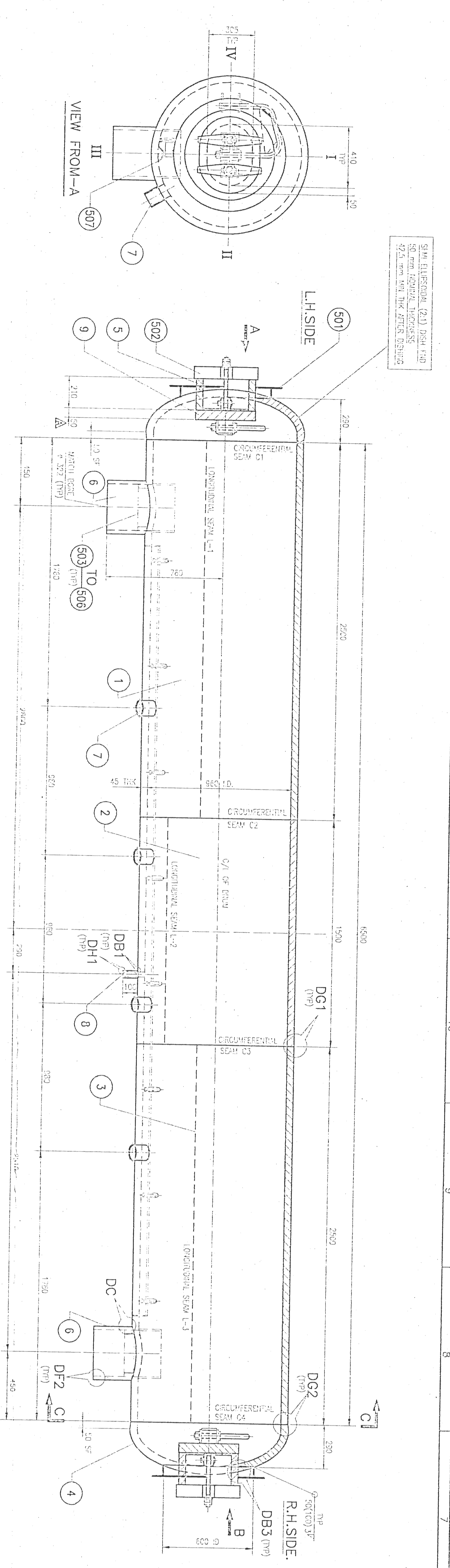

YIELDING DETAIL FOR STUD CONT. TO DRUM
AS PER BS-1113 PG. NO. C-49

| ITEM | QTY | UNIT | DESCRIPTION |
|------|-----|------|-------------|
| 1 | 1 | NO. | STUD |
| 2 | 1 | NO. | WELD |
| 3 | 1 | NO. | DRUM |

DETAIL AT DB1
DETAIL AT DB2

| ITEM | QTY | UNIT | DESCRIPTION |
|------|-----|------|-------------|
| 1 | 1 | NO. | DRUM |
| 2 | 1 | NO. | WELD |
| 3 | 1 | NO. | STUD |

EDGE PREPARATION AND PIPE TO PIPE WELDING DETAIL
DETAIL AT DB1

| ITEM | QTY | UNIT | DESCRIPTION |
|------|-----|------|-------------|
| 1 | 1 | NO. | DRUM |
| 2 | 1 | NO. | WELD |
| 3 | 1 | NO. | STUD |

STAND PIPE EDGE PREPARATION DETAIL
DETAIL AT DB

| ITEM | QTY | UNIT | DESCRIPTION |
|------|-----|------|-------------|
| 1 | 1 | NO. | DRUM |
| 2 | 1 | NO. | WELD |
| 3 | 1 | NO. | STUD |

DETAIL AT P

| ITEM | QTY | UNIT | DESCRIPTION |
|------|-----|------|-------------|
| 1 | 1 | NO. | DRUM |
| 2 | 1 | NO. | WELD |
| 3 | 1 | NO. | STUD |

DETAIL AT DC

| ITEM | QTY | UNIT | DESCRIPTION |
|------|-----|------|-------------|
| 1 | 1 | NO. | DRUM |
| 2 | 1 | NO. | WELD |
| 3 | 1 | NO. | STUD |

DETAIL AT DB

| ITEM | QTY | UNIT | DESCRIPTION |
|------|-----|------|-------------|
| 1 | 1 | NO. | DRUM |
| 2 | 1 | NO. | WELD |
| 3 | 1 | NO. | STUD |

GENERAL NOTES

CLIENT:- M/S. OSWA, CHEMICALS & FERTILIZERS LTD., ORISSA
MANUFACTURED BY:- M/S. THERMAX LTD., RAJAHMUNDRAM
LIMITED PAPER 411 004
WATER DRUM
SR.NO.9
P31-07B-04365